



Compact Fluorescent

**Brushed Nickel with
Alabaster Glass**

Sconce

Type _____
 -09 -09EBWB
 P7091

Catalog No.	Finish Brushed Nickel	Lamping	Socket	Dimensions (Inches)			
				A	B	C	D
P7091	-09	1-13w 2 pin Twin Not Included	GX23	11-3/4	5-3/4	6-5/8	2-1/4
P7091	-09EBWB	1-13w 4 pin Quad Included	G24q1	11-3/4	5-3/4	6-5/8	2-1/4

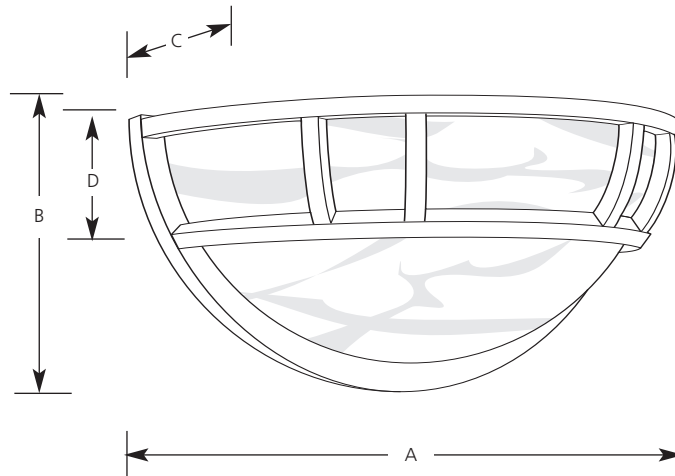

Specifications:

General

- Alabaster glass diffuser
- Half of a hemisphere shape
- Brushed nickel trim
- Plated finish on trim
- Steel construction
- P7091-09EBWB is a Certified Energy Star product

Electrical

- Pre-wired
- P7091-09 has a 120 volt NPF magnetic ballast
- P7091-09EBWB has a 120 volt NPF electronic ballast

Labeling

- UL-CUL listed

Mounting

- Vertical wall mount
- Covers outlet box
- Mounting strap for outlet box included



Progress Lighting
 Post Office Box 5704
 Spartanburg, South Carolina
 29304-5704

www.progresslighting.com